



STB500T5

SANY TELESCOPIC BOOM
CRAWLER CRANE



160 t·m



44 m



44 m + 16 m

www.sanygroup.com

QUALITY CHANGES THE WORLD

The parameters, pictures and standard/optional equipment are only for reference in this brochure, the actual machine is based on the effective price list and contract.

V1.0

01

04 / INTRODUCE

04

08 / TRANSPORT DIMENSION

02

06 / OUTLINE DIMENSION

05

09 / TRANSPORT PLAN

03

07 / MAIN PERFORMANCE
PARAMETERS

06

10 / MAIN CHARACTERISTICS
Product Specification
Safety Device

07

13 / CONFIGURATIONS

Working Range of H
Load Chart of H
Load Chart of FJ

01 | Introduce

Strong Capability

- U-shape large profile boom with max. lifting moment 160t.m.

Convenient Transfer

- Fully retracted width 3m, only 1 trailer needed for the whole machine transportation.

Simple and Reliable

- Car-level operation experience, a more seamless human-machine interaction interface, third-generation intelligent control system, one-button start/stop, 10.1" dual touchscreen display, intelligent and convenient.

High Efficiency

- Combined motions are carried out efficiently, with each motion starting and braking smoothly.



STB500T5
TELESCOPIC BOOM CRAWLER CRANE



02 | Outline Dimension

STB500T5

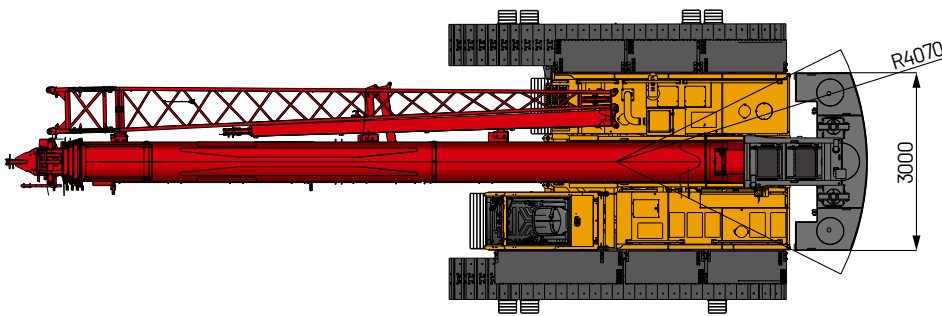
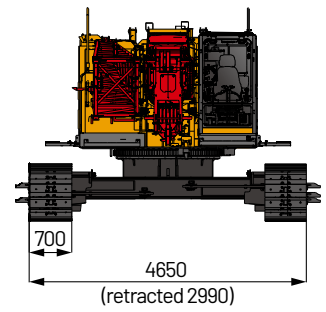
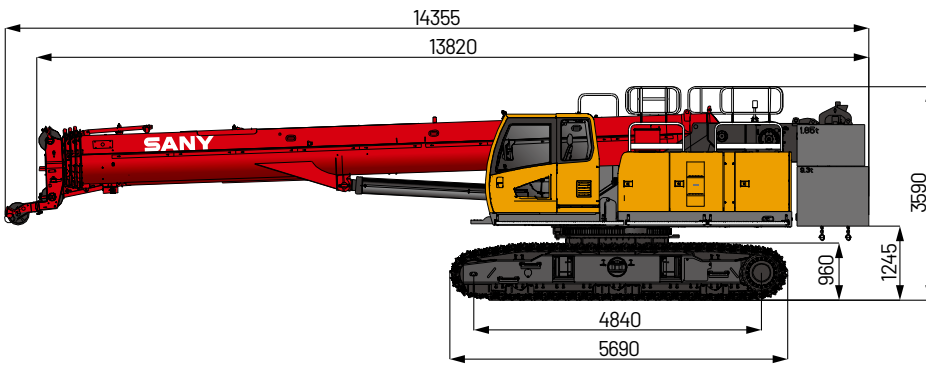

Unit: mm



03 | Main Performance Parameters

Performance Indicators	Unit	Parameter
Outline Dimension		
Length	mm	14355
Width (retracted)	mm	4650 (3000)
Height	mm	3590
Distance between the center of drive sprocket and idler	mm	4840
Width of track pad	mm	700
H		
Max. rated lifting capacity	t	50
Boom length	m	11.3~44
Boom angle	°	-2~78
Max. rated lifting moment	t·m	160
FJ		
Longest main boom + longest jib	m	44+16
Jib angle	°	0, 15, 30
Speed		
Rope speed of main/aux. winch (the outermost work layer)	m/min	0~120
Time to fully luffing up/down of boom	s	50/60
Time to fully extension/retraction of boom	s	110/120
Slewing speed	rpm	2
Travel speed (no-load)	km/h	0~3
Drive Motor		
Model	-	Cummins B6.7-C225
Rated power	kW/rpm	168/1800
Wire Rope		
Diameter	mm	Φ16
Transport		
Gross weight	t	48.2
Max. transport weight of single piece	t	34.5 (without rear counterweight, main hook and auxiliary hook)
Transportation dimension (L × W × H)	mm	13820 × 3000 × 3265
Other Parameters		
Average ground pressure	Mpa	0.07
Min. swing radius	mm	4070

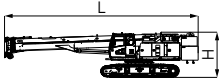
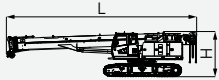
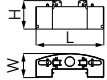
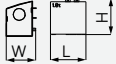
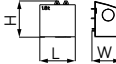
04 | Transport Dimension

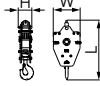
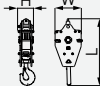
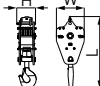
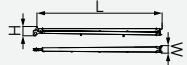
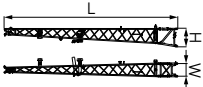
No.	Item	Shape	Length (m)	Width (m)	Height (m)	Weight (t)	Quantity
1	Whole machine (full-counterweight)		13.82	3.00	3.26	48.2	1
2	Basic machine (with jib)		13.68	3.00	3.26	34.5	1
3	Counterweight tray		3.00	1.06	1.27	9.4	1
4	Rear counterweight 1		0.97	0.81	1.00	1.8	1
5	Rear counterweight 2		0.97	0.81	1.00	1.8	1
6	5t hook block		0.66	0.24	0.24	0.085	1
7	15t hook block		1.35	0.60	0.36	0.29	1
8	35t hook block		1.53	0.60	0.36	0.33	1
9	50t hook block		1.80	0.69	0.47	0.58	1
10	Slewing-away		6.80	0.38	0.50	0.25	1
11	Jib section		9.61	0.80	1.03	0.5	1

Note:
 This component's transportation dimensions are shown in the diagram and are not drawn to scale. The indicated dimensions are design values and do not include packaging.
 The weight is a design value, and due to manufacturing tolerances, it may vary slightly. The total weight of counterweights is 13 tons.
 After our company upgrades and updates the product, there may be changes in the external dimensions and weight of the above components. The final specifications will be based on the new product.

05 | Transport Plan

1 Transport Plan 1

Trailer	
Part (s)	▪ Basic machine × 1
Weight	▪ 48.2t

Note: The handrail can be folded during transport.

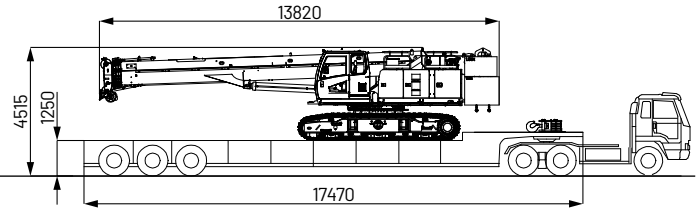

2 Transport Plan 2

Trailer 1	
Part (s)	▪ Basic machine × 1
Weight	▪ 34.5t

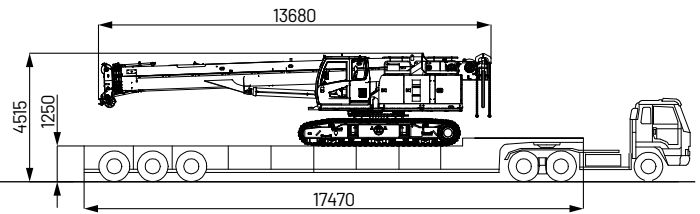

Trailer 2	
Part (s)	▪ Main hook × 1 ▪ Auxiliary hook × 1 ▪ Counterweight × 1
Weight	▪ 13.7t

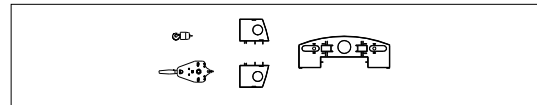
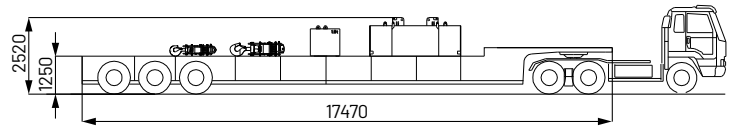

06 | Main Characteristics

1 Product Specification

Engine

- Model: Cummins B6.7-C225 Diesel engine.
- Type: 4-stroke, water-cooled, vertical in-line 6 cylinders, direct injection, turbo-charger, intercooler, complied with european off-highway stage V emission standard.
- Displacement: 6.7L.
- Rated power: 168kW/1800rpm.
- Operation power: 168kW/1800rpm.
- Max. Torque: 1186N·m/1300rpm.
- Starter: 24V-7.8kW.
- Cooling system: Pressurized water circulating system with temperature adjustable.
- Radiator: Fin type aluminum plate core.
- Air cleaner: Dry type system with main filter element, safety element.
- Throttle: Foot throttle, electrically-controlled.
- Fuel filter: Replaceable paper element.
- Batteries: Two 12V × 165Ah capacity batteries, connected in series.
- Fuel tank capacity: 400L.

Electrical Control System

- Adopt SYIC-III integrated control system independently researched and developed by Sany. This system is featured by high integration level, accurate operation and reliable quality.
- Control system: Composed of power system, engine system, main control system, Load Moment Limiter, auxiliary system and safety monitoring system. Data communication among controller, display and engine is conducted by CAN bus technology.
- Display: It can display the engine rotating speed, fuel volume, engine oil pressure, servo pressure, wind speed, engine working time, load weight, boom angle and other working parameters and working conditions.

Hydraulic System

- Main pump: Adopt high-power open variable displacement piston pump, providing power for the entire machine.
- Gear pump: Dual gear pump are used for slewing and servo functions.
- Control: The main pump adopts the control type of electrically proportionate positive flow. The operating components are two electric-controlled cross handles, one electric control pedal valve for boom telescoping, and one dual electric pedal control valve for travel, to control each actuator proportionally.
- Way of cooling: Heat exchanger, fan core and multi-stage cooling.
- Filter: Large flow, high accuracy filter, with bypass valve and indicator, which can remind the user to replace the filter element in time.
- Max. pressure of system:
Main load, aux. load, and travel system: 32MPa.
Boom hoist cylinder lifting: 32MPa.
Swing system: 24MPa.
Control system: 4.5MPa.
- Hydraulic tank capacity: 640L.

Main and Aux. Hoist Winch

- Pump and motor: Dual-placement speed controlled energy efficient, combination of winch balance valve and anti-hook sliding technology, lifting or lowering the load steadily.
- Winch brake adopts concealed, normally closed, wet type and spring loaded fin type normally engaged brake, spring force braking, oil pressure released.
- Main and aux. load hoist winches adopt piston motor of variable displacement to drive planetary reducer.

Main hoisting winch	Rope speed on the outermost work layer	0~120m/min
	Wire rope diameter	Φ16mm
	Wire rope length of main hoist	220m
	Rated single line pull	4.6t
Auxiliary hoisting winch	Rope speed on the outermost work layer	0~120m/min
	Wire rope diameter	Φ16mm
	Wire rope length of auxiliary hoist	135m
	Rated single line pull	4.6t

Luffing Mechanism

- Dual-acting single piston hydraulic cylinder, with safety balance valve, and a luffing angle of $-2^{\circ} \sim 78^{\circ}$. Luffing down through self-weight to reduce energy consumption and increase stability of luffing down operation.

Slewing Mechanism

- Slewing brake adopts concealed, normally closed, wet type and spring loaded disc brake, spring force braking oil pressure released.
- Slewing system adopt integrated slewing buffer valve, three slewing modes can be selected (anti-slip/semi-drift/drift). providing smooth slewing start & stop and excellent inching performance.
- Unique swing cushion design ensures more stable braking.
- Slewing drive: External gearing swing drive, capable of conducting 360° slewing, maximum slewing speed 2r/min. The maximum driving pressure can reach 24MPa.
- Swing lockout: Locking device, to ensure that the superstructure can be locked in front and rear directions conveniently and reliably during off-work time and transportation.
- Swing bearing: Single row ball bearing.

Counterweight

- Standard counterweight self-assembly function, the combination counterweight blocks are easy to assemble and disassemble, making transportation more convenient.
- Using a pallet and counterweight block combination method, facilitating assembly, disassembly and transportation.
- Rear counterweight: 13t.

Superstructure

- The high-strength steel welded frame structure provides better resistance to deformation and torsion. It features a closed protective cover for enhanced protection. The component layout is rational, making maintenance and service more convenient.

06 | Main Characteristics

1 Product Specification

Cab and Controls

- Novelty in cab design, artistic modeling and trim and large area glass window with a tilt angle of 20° to broaden horizon, fitted with low beam headlamp and rear-view mirror to broaden horizon, installed with air conditioner and radio, the arrangement of seats, control handle and various control buttons is ergonomically designed to enable more conformable operation.
- Cab layout: Dual 10.1-inch touch screen, programmable smart switches, and improved touch screen interference.
- Armrest box: On the left and right armrest box are control handles, electrical switches, emergent stop and ignition switch. The armrest box can be adjusted along with the seat.
- Seat: Multi-way and multi-level floating adjustable seat with unload switch.
- A/C: Cool and heat air, optimized air channels and vents.
- Multiple cameras can be displayed on the monitor at the same time to realize backing video, real-time monitoring of wire rope on each winch, conditions behind the counterweight and surrounding the machine.

Travel Drive

- Independent travel driving units are adopted for each side of the crawler, to realize straight walking and turning driven by travel motor through gearbox and drive wheel.
- There are high-speed and low-speed for travel as fast as 3km/h.
- Gradeability is 45%.

Traveling Braking

- Embedded, wet, spring-loaded and normally-closed brake, which is braking with spring force and released by oil pressure.

Side Frame Extension and Retraction

- The extension and retraction of crawler frames are realized through electric control cylinder. The crawlers are extended at work and retracted for transport with the whole basic machine.

Crawler Tensioning

- Spring tensioner with auxiliary hydraulic cylinder regulates the tension degree through charging grease, and the spring can perform buffer and protection function when traveling.

Steering System

- It can realize single track turning and pivot turning.

Track Frame

- 190C reinforced double-bar track frame is adopted, which is made of high strength alloy cast steel, has stronger road holding capacity and longer service life, and can adapt to various harsh road conditions. Width 700mm, Qty 62x2.

Track Roller

- Maintenance-free track roller.

Outrigger

- Not

Boom

- The boom is made of high-strength steel structure with U-shape section area, with five sections, of which the basic boom is 11.3m and the max. boom length is 44m.
- Dual cylinders and rope row for boom telescoping.

Fixed Jib

- Bi-fold fixed jib length of 9.2m and 16m.
- Offset angle includes 0°, 15° and 30°.

Tip Pulley

- Welding structure, connected with the boom through pin, and used for auxiliary hook operation.

Hook Block

No.	Capacity (t)	No. of sheaves	Weight (t)	Quantity
1	50	5	0.58	1
2	35	3	0.33	1
3	15	1	0.29	1
4	5	0	0.085	1

Note: the above-mentioned operating equipment is full-up configuration. The actual configurations are subject to contract.
* marked as optional material

Hook limitation height

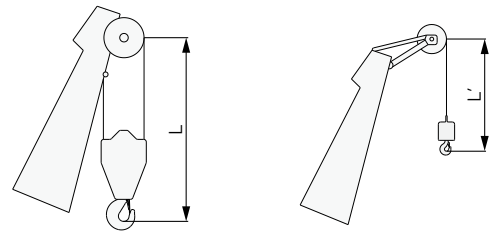

Hook	L	Hook	L'
50t	3.4m	5t	2.8m
35t	3.4m		
15t	3.4m		

06 | Main Characteristics

2 Safety Device

Load Limit Indicator (LMI)

- The integrated LMI system is provided as standard and high safety and efficiency for equipment control.
- The LMI system can automatically detect the suspended load weight, working radius of the crane and the angle of boom, and compare rated load weight and actual load, working radius and boom angle. Under normal operation condition, it can intelligently judge and automatically cut off the crane action in dangerous direction, and have black box function to record the overload information.
- Its main components include: monitor, controller, length and angle sensor, pressure sensor, etc.

Assembly / Working Mode Switching Switch

- The assembly mode is primarily used for scenarios such as the disassembly of the boom or the removal of counterweights. In Assembly Mode, height limit and boom angle limit are disabled to facilitate crane assembly
- In Work Mode, all safety limiting devices activate to protect the operation.

Emergency Stop

- The left armrest box in cab is equipped with one emergency stop button. In emergency situation, this button is pressed down to cut off the power supply of the whole machine and all actions stop.

Over-hoist Protection of the Main / Auxiliary Load Hoist

- A2B limit switch is equipped on the boom/jib tip, which prevents the hook lifting up too much. When the hook is lifted up to the limit height, the limit switch activates, alarm pops up on the monitor, buzzer on the right front control panel sends alarm, failure indicator light starts to flash and the hook hoisting action is cut off automatically.

Over-release Protection of the Main / Auxiliary Load Hoist

- Three-wrap protector is installed on main and aux. load hoist to prevent over-release of wire rope. When the rope is paid out close to the last three wraps, the limit switch acts, and the system sends alarm through buzzer and show the alarm on the monitor, automatically cutting off the winch action.

Function Lock

- There is a function lock lever located on the right side of the driver's seat in the cab. If the function lock lever is not in work position, all the other handles won't work, which prevents any mis-operation caused by accidental hitting.

Hook Latch

- The lifting hook is installed with a baffle plate to prevent wire rope from falling off.

GPS Monitoring System

- Remote monitoring system is a standardized offering to provide functions like GPS locating, GPRS data transfer, machine status inquiry and statistics, operating data monitoring and analysis, remote diagnosis of failures.

Tri-color Load Indicator

- The load indicator light has three colors, i.e., green, yellow and red; and the real time load status is presented on the display. When the actual load is smaller than 90% of rated load, the green light is on; when the actual load is larger than 90% and smaller than 100%, the yellow light is on, the alarm light flashes and sends out continuous sirens; when the actual load reaches 100% of rated load, the red light is on, the alarm light flashes and sends out continuous sirens. At this moment, the system will automatically cut off the crane's dangerous operation.

Flash Alarm

- When the LMI is powered on, the flash alarm will turn on.

Slewing Indicator Light

- The slewing indicator light flashes during traveling or slewing.

Seat Interlock Protection

- If the operator leaves the seat, all control handles and switches will be disabled immediately to prevent any mis-operation due to accidental collision.

Illuminating Light

- The machine is equipped with short-beam light in front of machine, lamps in operator's cab and lighting devices for night operation, as well as boom lights, so as to increase the visibility during work.

Rear View Mirror

- It is installed at the front of the operator's cab, at the right handrail of the platform and near the winches.

Level Indicator

- Electrical level indicator can show the inclination angle of superstructure on the monitor.

Monitoring System

- Cameras are installed on the winch box, tail of turntable and right side engine cover, which can display real-time monitoring images of the main and auxiliary winches, tail of turntable, and right side track pads on the cab's monitor.



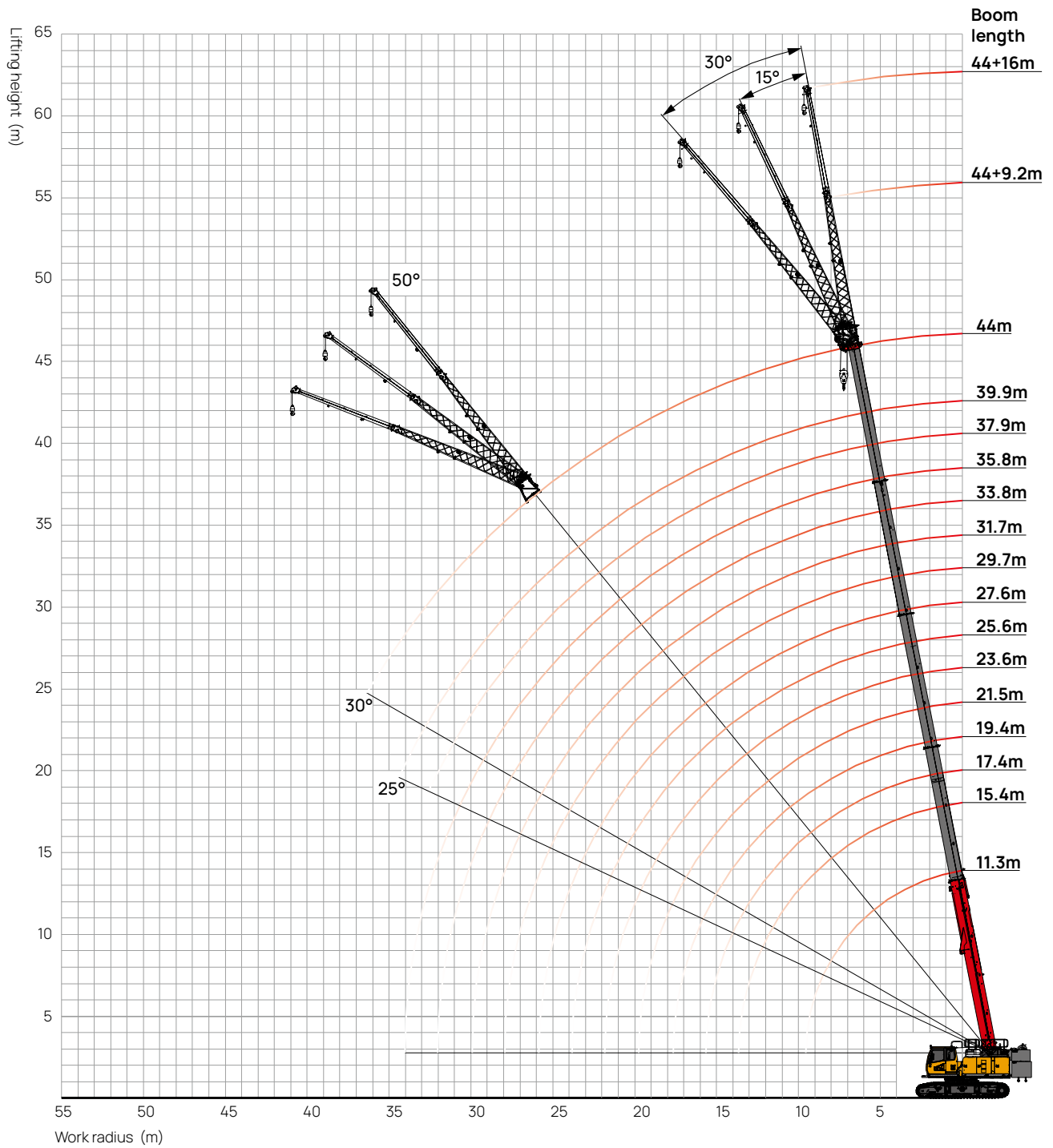

07 | Working Range of H

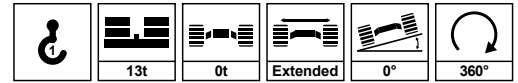

07 | Load Chart of H

Unit: t



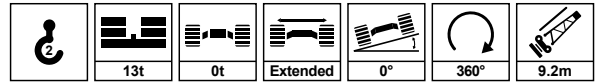

	Main Boom Length (m)																
	11.3	15.4	17.4	19.4	21.5	23.6	25.6	27.6	29.7	31.7	33.8	35.8	37.9	39.9	44.0		
2.5	50															2.5	
3	40	35														3	
3.5	35	34.5	18	28												3.5	
4	34.5	34	18	28	18	18										4	
4.5	33.5	33	18	28	18	18	18									4.5	
5	32	29.4	18	26.6	18	17.8	18	18								5	
5.5	28.1	25.9	18	23.6	18	16.9	18	17.2	13.2							5.5	
6	24.2	23.4	18	21.2	18	16.1	18	16.5	12.7	15						6	
7	19	18.8	18	17.4	18	14.8	16.6	15.3	11.7	13.6	11.5	9.2				7	
8	15.2	15	16.4	14.5	15.3	13.5	14.1	14.2	10.8	12.6	10.8	8.5	10	8.3		8	
9	12.4	12.3	13.6	12.1	13.1	12.5	12.2	12.7	10	11.8	10.1	8	9.1	7.8	7.6	9	
10		10.2	11.5	10.1	11.2	11.7	10.6	11.1	9.3	10.3	9.5	7.5	8.6	7.4	7.4	10	
12		7.3	8.6	7.2	8.2	9	8	8.7	8.1	8.1	8.3	6.6	7.7	6.6	6.8	12	
14			6.6	5.2	6.3	7	6.1	6.7	7.2	6.5	7	5.9	6.5	6	6.1	14	
16				3.8	4.8	5.6	4.6	5.3	5.9	5.1	5.6	5.3	5.3	5.4	5.3	16	
18					3.7	4.5	3.5	4.2	4.8	4	4.5	4.8	4.3	4.7	4.3	18	
20						3.7	2.7	3.4	4	3.2	3.7	4.1	3.5	3.9	3.7	20	
22							2	2.7	3.3	2.5	3	3.4	2.8	3.2	3	22	
24								2.2	2.7	1.9	2.3	2.9	2.2	2.6	2.5	24	
26									2.2	1.4	1.8	2.4	1.7	2.2	2	26	
28										1	1.4	2	1.3	1.8	1.6	28	
30											1.1	1.7	0.9	1.4	1.2	30	
32											0.6	1.3		1	0.9	32	
34												0.8		0.8		34	
	11	9	5	7	5	5	5	5	3	4	3	3	3	2	2		
	2#	0	50	0	100	50	0	100	50	0	100	50	0	100	50	100	2#
	3#	0	0	25	0	25	50	25	50	75	50	75	100	75	100	100	3#
	4#	0	0	25	0	25	50	25	50	75	50	75	100	75	100	100	4#
	5#	0	0	25	0	25	50	25	50	75	50	75	100	75	100	100	5#

07 | Load Chart of FJ





Unit: t

 m	44m+9.2m			 m
	0°	15°	30°	
10	3.4			10
12	3.2	2.8		12
14	3.1	2.5	2.1	14
16	2.9	2.3	2	16
18	2.6	2.1	1.9	18
20	2.3	1.9	1.8	20
22	1.9	1.7	1.7	22
24	1.5	1.4	1.6	24
26	1.2	1.2	1.3	26
28	0.9	1	1	28
30	0.7	0.7	0.8	30
32	0.5	0.5		32
34		0.4		34



Unit: t

 m	44m+16m			 m
	0°	15°	30°	
12	2.1			12
14	2			14
16	1.9	1.3		16
18	1.7	1.2	1	18
20	1.5	1.1	0.9	20
22	1.4	1	0.9	22
24	1.3	1	0.8	24
26	1.1	0.9	0.8	26
28	1	0.9	0.8	28
30	0.8	0.8	0.7	30
32	0.6	0.7	0.7	32
34		0.5	0.7	34

Zhejiang Sany Equipment Co.,LTD

SANY Crawler Crane Industrial Park, No. 2188 Daishan Road, Wuxing District, Huzhou City, Zhejiang Province, P. R. China Zip 313028
Consulting sanycrane@sanygroup.com (Crane BU) / crd@sany.com.cn (IHQ)
After-sales Service 0086-400 6098 318

Reminder:

Any change in the technical parameters and configuration due to product modification or upgrade may occur without prior notice.

The machine in the picture may include additional equipment. This brochure is for reference only, and goods in kind shall prevail.

Copyright at SANY. No part of this brochure may be copied or used for any purpose without written approval from SANY.

© Edited in July 2025



SANY CRANE



www.sanygroup.com